

Info tecniche

classe	I
potenza	5,7 W
flusso luminoso	640 lm
ottica	40°
resistenza alla rottura	IK 08
grado di protezione	IP 65
peso	2 kg
connessione elettrica	220-240 V 50-60 Hz

Colori

Inox	IN	
Browntech	BT	
Naturalblack	NB	



Descrizione prodotto

- Corpo interamente in acciaio inox AISI 316
- Diffusore in vetro trasparente
- Fissaggio a parete con cassaforma inox cod. RAW25CA
- Alimentatore elettronico interno
- Colore led 2700 e 3000 K
- Luce indiretta
- Rispetta le leggi contro l' inquinamento luminoso

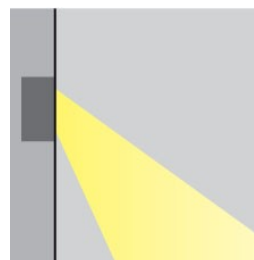

Disegno tecnico

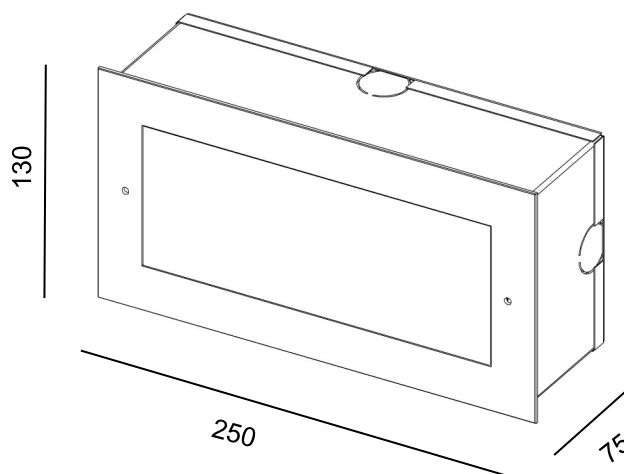

Info techniques

Classe	I
Puissance	5,7 W
Flux lumineux	640 lm
Optique	40°
Résistance à la rupture	IK 08
Degré de protection	IP 65
Poids	2 kg
Connexion électrique	220-240 V 50-60 Hz

Couleurs

Inox	IN	
Browntech	BT	
Naturalblack	NB	



Description du produit

Corps complètement en acier inoxydable AISI 316
 Diffuseur en verre transparent
 Fixation au mur par boîte de réservation réf. RAW25CA
 Transformateur électronique intérieur
 Couleur led 2700 et 3000 K
 Lumière indirecte
 Il respecte les normes contre la pollution lumineuse

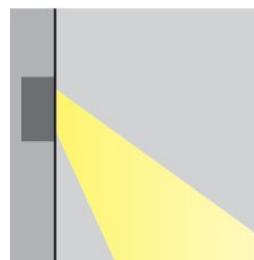

Dessin technique

